

COSUMNES RIVER COLLEGE 2015 ACCREDITATION SELF STUDY REPORT



SUPPLEMENT

Cosumnes River College

Supplemental Information Packet

In support of the

**Self Evaluation Report of
Educational Quality and Institutional Effectiveness**

Submitted by:

Cosumnes River College
8401 Center Parkway
Sacramento, CA 95823

September 2015

Table of Contents

Introduction	3
Updated Tables of Organization	
College-wide.....	4
Administrative Services and Student Support	5
Student Services and Enrollment Management	6
Instruction and Student Learning.....	7
President’s Staff.....	8
Supplemental Information for Standard I.B: Improving Institutional Effectiveness	
Cosumnes River College Planning Guide Revision	9
Program Review and Forecast Manual (PrOF) Revision	9
College Integrated Planning Systems (CIPS) Update.....	9
Strategic Plan Updates	9
Final Achievement Report	9
Supplemental Information for Standard II.A: Instructional Programs	
Curriculum Handbook Update.....	10
Course Assessment Updates	10
Program Overview and Forecast Reports (PrOF).....	11
Supplemental Information for Standard III.B: Physical Resources	
CRC Infrastructure—Hydronic Mods at Multiple Buildings	12
Regional Transit’s Blue Line to CRC Extension.....	12
Facilities Request Process and Form Update.....	12
Supplemental Information for Standard III.C: Technological Resources	
Distance Education Master Plan Update.....	12
Supplemental Information for Standard IV.A: Decision-Making Roles and Processes	
Participatory Governance Handbook: Final Version.....	13
Associated Students (ASCRC)	13
Supplemental Information for Standard IV.B: Decision-Making Roles and Processes and Eligibility Requirements 4 & 5	
Dr. Edward Bush Appointed CRC’s New President	13
Dr. Kimberly McDaniel Appointed Chief Student Services Officer.....	14
LRCCD Governance Structure Graph	15
Appendix A	16
List of Sources	18

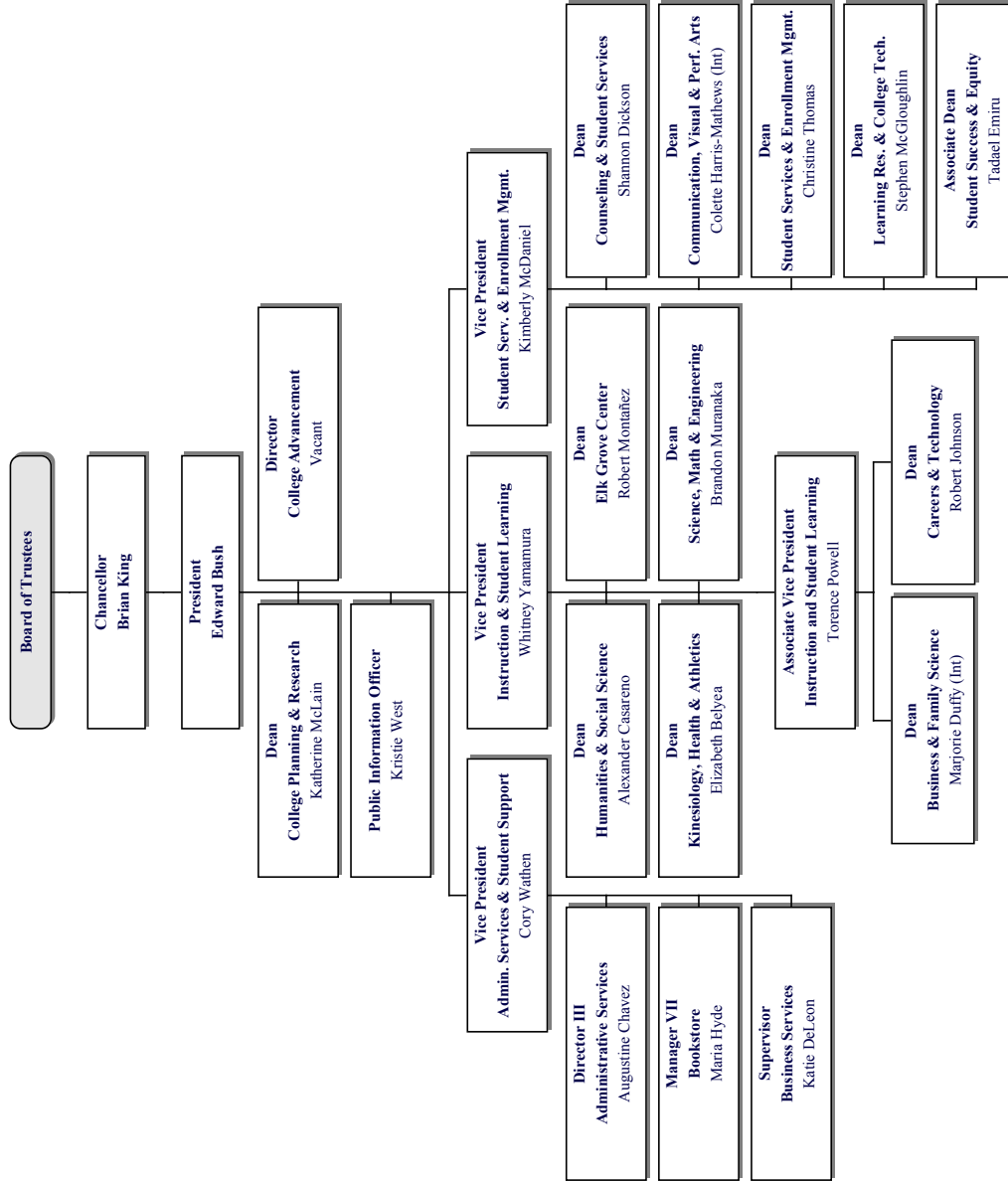
Introduction

The culture of Cosumnes River College celebrates continuous quality improvement. The College continues to grow and change in an effort to meet the diverse needs of the community it serves. Hence, since the printing of Cosumnes River College's 2015 Institutional Self Evaluation Report in July 2015, processes, plans, and staffing have evolved and improved. This supplemental information packet is designed to explain some of the more significant changes as they relate to the Accreditation Standards.

The Tables of Organization on the following page reflect staffing changes at the College. Since July, the College has hired a new College President and Vice President of Student Services, as well as two Interim Deans, Supervisors, and others. Subsequent updates include information relevant to Standards I.B, II.A, III.B, III.C, IV.A, IV.B and Eligibility Requirements 4 and 5.

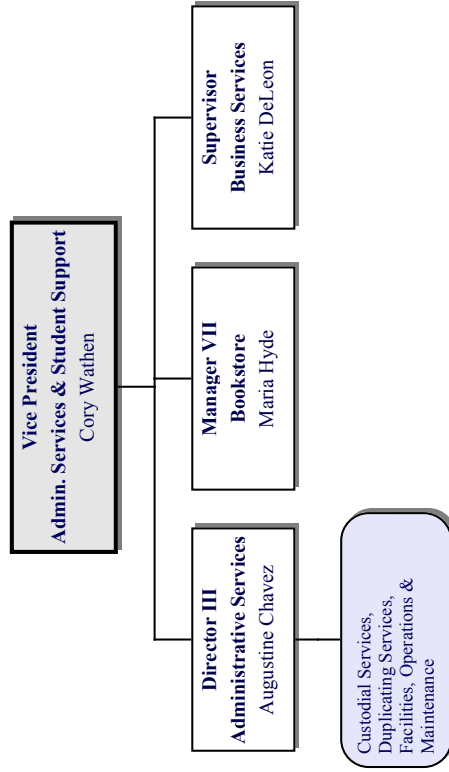


Table of Organization - Cosumnes River College



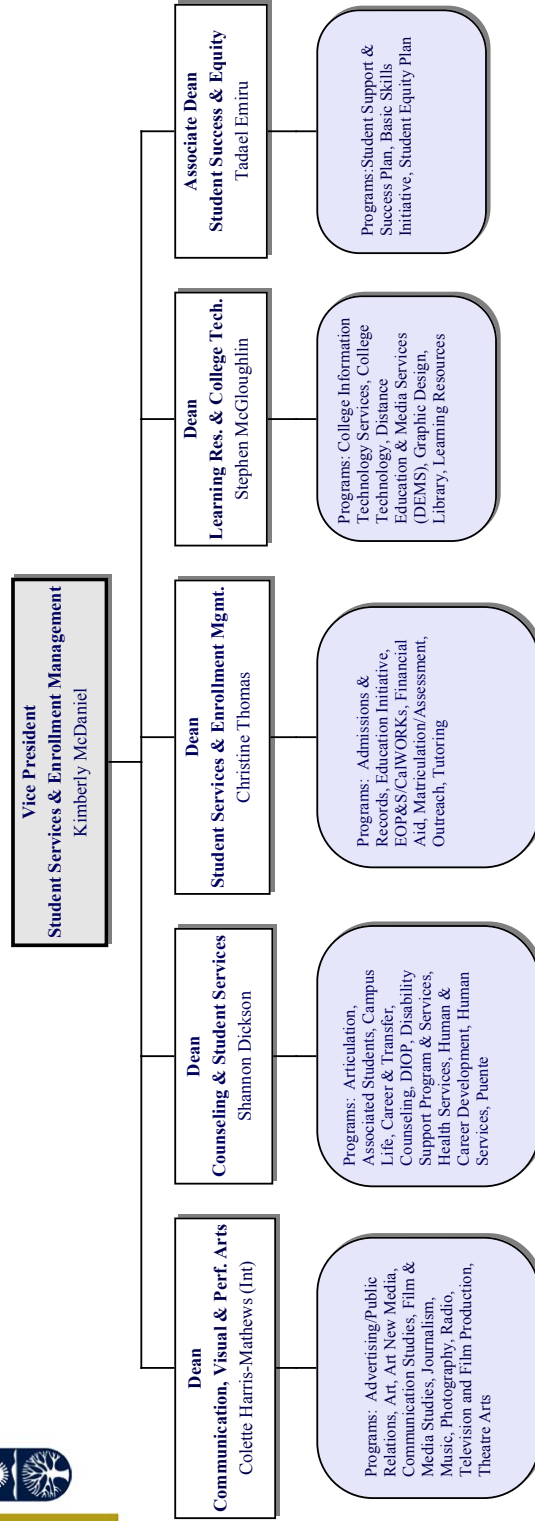


**Table of Organization - Cosumnes River College
 Administrative Services and Student Support**



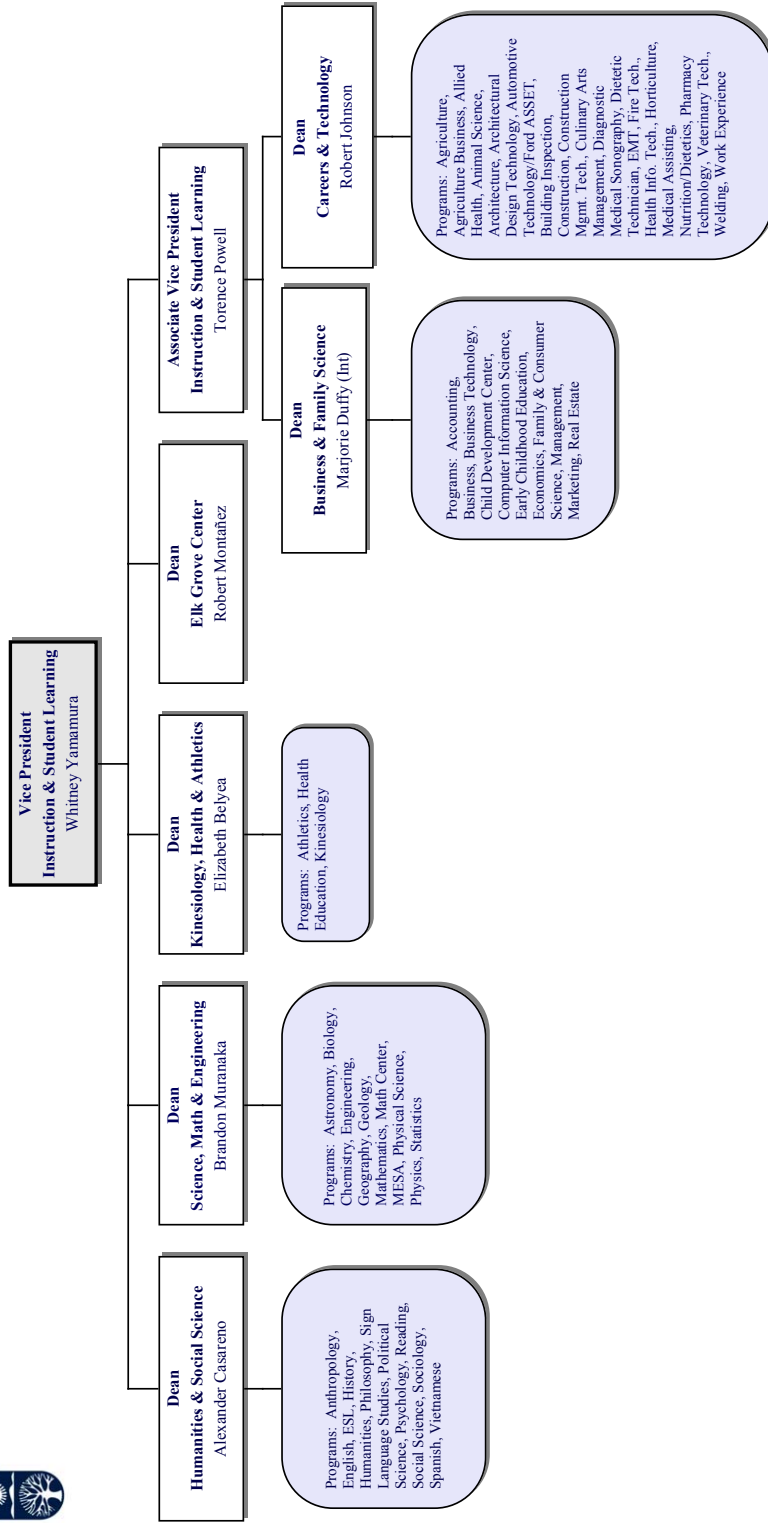


**Table of Organization - Cosumnes River College
Student Services & Enrollment Management**



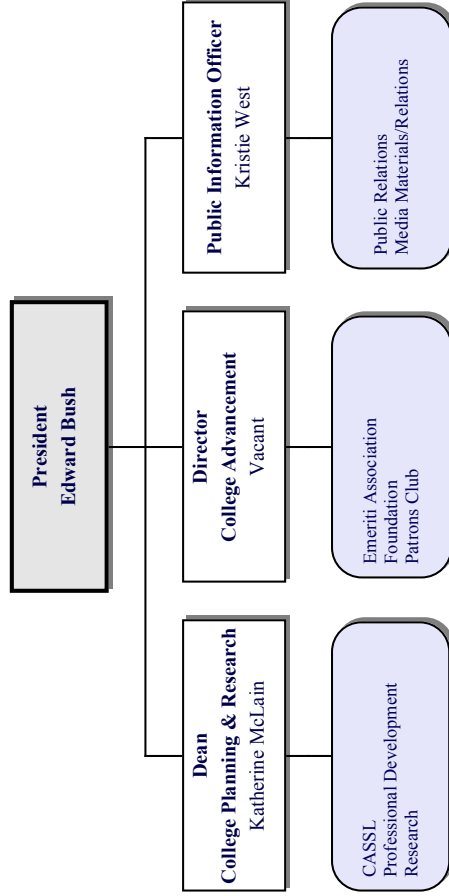


**Table of Organization - Cosumnes River College
Instruction & Student Learning**





**Table of Organization - Cosumnes River College
 President's Staff**



Supplemental Information for Standard I: Institutional Mission and Effectiveness

Updates for Standard I.B: Improving Institutional Effectiveness

College planning documents must be regularly revised to reflect changes and updates in language and process. The following links provide the most recent versions of planning documents revised during the Spring/Summer of 2015:

1. [Cosumnes River College Planning Guide](#) Revision: This Planning Guide provides information about the College's integrated planning and budgeting processes. The processes in this document identify ways the constituent groups participate in, and contribute to, the College's long-term and short-term planning. This document begins with a description of the College's Integrated Planning Model. A description of the process and timeline for each component in the model follows the overview. The previous [\(2009-2015\) version of the Planning Guide](#) is also available for review.
2. [Program Overview and Forecast Manual \(PrOF\)](#) Revision: This manual provides information about the role and function of PrOF as well as specific directions to help faculty and staff successfully navigate the mid-term PrOF process. The purpose of Program Review is to periodically evaluate the impact of internal and external changes and assess various indicators of program effectiveness to proactively plan for the future. Although many of these plans can be implemented at the program level, some of the plans need institutional support or have college-wide impact. For this reason, the PrOF process also informs unit planning, college-wide planning and all college resource allocation processes. The [previous PrOF Manual](#) is also available for review.
3. [College Integrated Planning System \(CIPS\)](#) Update: The url and homepage for CIPS was recently updated. The goal of this system is to integrate the various college planning processes and forms into one online system that leverages the inter-connected nature of the planning process. Currently, the request for resources is a separate form that requires departments to import, or "cut and paste," their information from PrOF to demonstrate request alignment with planning processes. As the updated CIPS homepage explains, the College is working towards a more streamlined planning system. The [previous url for CIPS](#) is also available for review.

Currently, there are no Unit Plans in the updated CIPS system because 2015 PrOFs are not due until the end of the year. However, archived [Unit Plans from 2007, 2009, 2011, and 2013](#) are available for review.

4. Strategic Plan Updates: The College recently updated strategic plans for two committees. The [Cultural Competency and Equity Strategic Plan](#) and the [Professional Development Strategic Plan](#) provide goal setting, and other, important information.
5. Final Achievement Report: Each year, the College summarizes desired outcomes in a Final Achievement Report. The [2014-15 Final Achievements \(with benchmarks\)](#) is now available for review.

Standard II: Student Learning Programs and Services

Updates for Standard II.A: Instructional Programs

Curriculum Handbook Update

The newly revised [Curriculum Handbook](#) was written as part of a sabbatical project by the Curriculum Chair. The revised Curriculum Handbook was reviewed and approved by the Curriculum Committee and the Academic Senate. In early August, the final document was uploaded to the CRC website (under the Curriculum Committee's documents), and the link was emailed to all faculty. Recent revisions made to this document clarify curriculum processes and articulate steps faculty must follow to construct and submit curriculum proposals. Specific changes to the revised handbook include: an updated curriculum committee charge, an updated explanation of distance education additions to course proposals (related to new fields in SOCRATES per an update in March 2015), the inclusion of an Associate Degrees for Transfer (ADT) explanation, an explanation of how to calculate credit hours, and revisions to course repetition and repeatability based on the new legislation.

Course Assessment Update

During late Spring 2015, faculty leads in each Instructional Division reminded colleagues scheduled to assess their courses during Spring 2015 to complete assessment tasks by the semester's end, or when they revised their syllabi prior to the start of Fall 2015 classes. At the beginning of the Fall 2015 semester, Instructional Deans notified faculty scheduled to assess courses in Spring 2015, Fall 2015, and Spring 2016 of their course assessment schedules. As of early Fall 2015, more than 420 courses have been assessed; some include multiple assessments by teaching faculty. There are four years remaining in the College's six-year course assessment cycle. The new SLO Faculty Coordinator for 2015-16 served as one of the faculty assessment leads in Spring 2015. The SLO Coordinator is prepared to support new faculty through future cycles of the assessment process.

During the summer, the updated assessment plans were entered into PrOF. The assessment reporting system exists within the College Integrated Planning System (CIPS); in this way PrOF and SOCRATES data are fully integrated into the College's planning system. This integration, combined with recent modifications in PrOF, enhance the ability of faculty and staff to update and monitor their assessment schedules within PrOF. These modifications allow the institution to monitor the implementation of program and course/activity assessment plans across the College. In addition, they provide access to real time data extracted from the assessment, SOCRATES, and PrOF systems.

A detailed explanation of the College's assessment outcomes evolution is described in the recently revised, [Brief History of the College's Outcomes Assessment Development Process](#). [The previous Assessment Outcomes History](#) is also available.

In addition, the most recently revised copy of the College's [Assessment Guide](#) is available for review. [The previous Assessment Guide](#) is also available.

Finally, Convocation provides another opportunity for the College to engage in broad-based dialogue about assessment. The details of more recent discussions are described in the [Fall 2015 Convocation Assessment Dialog Notes](#) and [Spring 2015 Convocation Assessment Dialog Notes](#).

Program Overview and Forecast Reports (PrOF)

The Self Evaluation Report includes a detailed discussion of the College's Program Review process and access to [2014 PrOF Data Packets](#). Since the College's Self Evaluation Report was printed, [2015 PrOF Data Packets](#) have been released. These new PrOF reports include additional data elements such as WSCH, FTE and productivity. In addition to college-wide and academic program review, the latest PrOF review cycle includes additional student services programs including CalWorks, CARE, DIOP, DSP&S, EOP&S, Foster Youth, MESA, Puente, and the Veterans Program.

Standard III: Resources

Updates for Standard III.B: Physical Resources

CRC Infrastructure—Hydronic Mods at Multiple Buildings (aka the “Big Dig”)

Since last spring, contractors have been excavating several sites across the campus to replace old hydronic lines, which supply the water to heat and cool most of the buildings and provide hot/cold water for sinks, showers, etc. At the end of this project, a large section of the main infrastructure lines will be replaced with newer, longer lasting Perma-Pipe. The project will reduce leaks and improve water flow to improve effectiveness of the heating/cooling system and sustainability. New valves and y-strainers (used to filter water) are installed and should improve water flow to our HVAC systems. The project has impacted the walkway between the Library building and the Community & Athletic Center. The project is scheduled to be completed by November 1.

Regional Transit’s Blue Line to CRC Extension

After years of planning and construction, Regional Transit’s (RT) Blue Line to CRC Extension and Station opened August 24, 2015. The new light rail station serves as a transit hub connecting RT, Elk Grove’s (etran), Paratransit and other transit buses and light rail. The Blue Line light rail provides direct access from CRC to Sacramento City College, which benefits students taking classes at both colleges. The 4.3 mile extension also brings increased access to higher education for the community. Currently four of every 10 Los Rios students use RT’s bus and light rail system, totaling 30,000 each day. Last year those students accounted for 4.4 million rides on RT.

Facilities Request Process and Form Update

The College continues to refine the processes through which facilities requests flow. The recently revised [Facilities Request Process \(2015-17\)](#) is now available for review, along with the related [Facilities Request Form \(2015-17\)](#).

Updates for Standard III.C: Technological Resources

Distance Education Master Plan Update

The [CRC DE Master Plan](#) is reviewed biennially—on non-Instructional Technology and Multimedia Budget (ITMB) years—by the Distance Education and Instructional Technology (DEIT) Participatory Governance group for currency, progress, and effectiveness. The DE Master Plan is revised and rewritten by this group to keep it relevant and in sync with policy changes and instructional technology developments. The most recent review was conducted by the DEIT group in May 2015 (group editing of a Google doc), as presented in that group’s minutes and annual year-end report to the Academic Senate and College President. Unfortunately, the group missed updating a column heading to the current year. Subsequently, a version went out showing “2011” instead of the correct 2015 as the header for the “Current Status” column. However, the information provided in that column is current and correct for the 2015 revision. The 2015 revision is available to our constituents on the DEIT section of the college website. It is also provided as part of evidence collection provided with the College’s Accreditation Self Evaluation for section IIIc.

Standard IV: Leadership and Governance

Update for Standard IV.A: Decision-Making Roles and Processes

Participatory Governance Handbook: Final Version

The College has standing participatory governance committees in which students, classified staff, faculty, and the administration come together to govern the College's activities. There are additional ad-hoc committees and task forces to work on specific issues. At the end of each school year, the chair of each participatory governance committee submits a year-end report to the Academic Senate and Executive Council on the work accomplished during the year. In addition, the committees regularly review and update their charters. The [Participatory Governance Handbook](#) details this process. The Handbook was still in draft form during Spring 2015, but is now finalized and available for review.

Associated Students (ASCRC)

The [Student Senate](#) serves as the recognized voice of the students on campus, and operates under the direction of officers who are elected by the CRC Student Body. The organization is the vehicle through which students may actively influence college life. Students who serve on college and district wide communities are appointed by the ASCRC President. The Student Senate is dedicated to serving the student body by specifically helping to promote the interests and rights of the students it represents. Please refer to Appendix A for the most recent list of students appointed to participatory governance committees.

Updates for Standard IV.B: Board and Administrative Organization and Eligibility Requirements 4 & 5

Dr. Edward Bush Appointed CRC's New President

After a semester long national search, the Los Rios Community College District Board of Trustees appointed Dr. Edward Bush as the new president at Cosumnes River College on July 1, 2015. Dr. Bush came to the College from southern California where he served as the Vice President of Student Services for Riverside City College. He has more than 20 years of experience in higher education with 15 of those years at the Riverside Community College District where he served on numerous college and district-wide committees and was active with several community organizations including serving on the board for two non-profit foundations. Dr. Bush has also worked as an adjunct instructor for the Graduate School of Education at the University of Redlands and at Brandman University. Dr. Bush has taught courses in student development, organizational theory, and research.

Dr. Bush received his Bachelors of Arts degree in Political Science from University of California, Riverside, a Master's degree in Public Administration from California State University, San Bernardino, and his Ph.D. in Educational Leadership from Claremont Graduate University. Dr. Edward Bush is a published author with eight peer reviewed publications appearing in journals including: *Black Issues in Higher Education*, *Community College Week*, *Diverse Educational Horizons*, *Journal of African American Males in Education*, and the *Community College Journal*. Dr. Bush is a founding member and President of the African American Male Education Network and Development (A2.M.E.N.D). In 2009, Dr. Bush was

recognized by the Riverside Chapter of the NAACP with the Drum Major Award in Education at their annual freedom fund dinner.

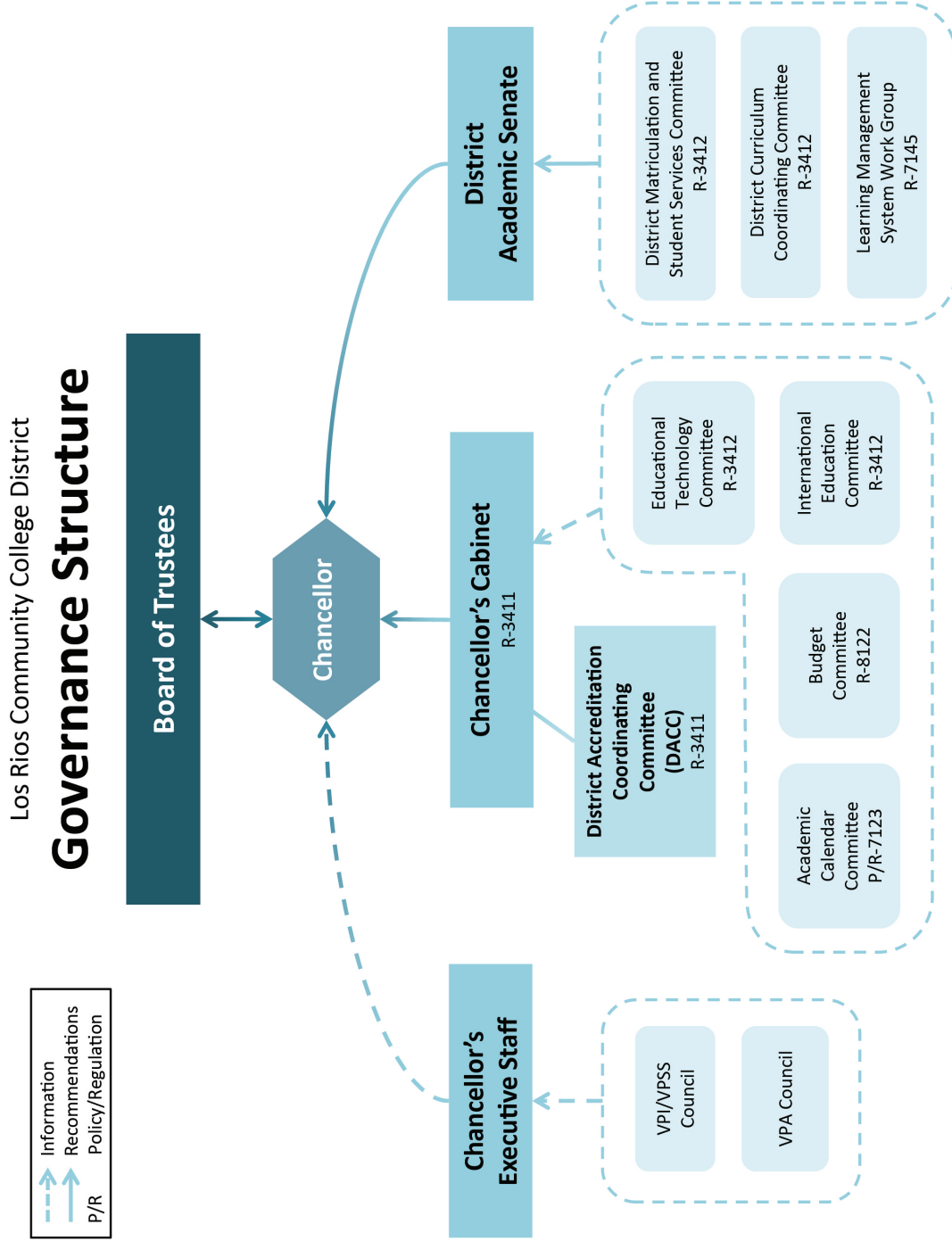
Dr. Kimberly McDaniel Appointed Chief Student Services Officer

Dr. McDaniel was appointed the new Vice President of Student Services and Enrollment Management at Cosumnes River College in July 2015 after a full search conducted in the Spring of 2015. Previously, she served as the Dean of Counseling and Student Services at Sacramento City College. Dr. McDaniel has also worked at the California Community College Chancellor's Office as the Matriculation Coordinator and at the California Children and Families Commission as the Program Development Officer. She earned her Bachelor of Arts in Psychology from UC Berkeley and has a Master of Arts in Educational Administration from CSU Northridge, and a Ph.D. in Education from the University of Southern California.

LRCCD Governance Structure Graph

The District articulates expectations to the four colleges and has clearly defined roles of authority and responsibility. District-wide committees meet regularly and communication is on-going as discussed in Standard IV.B.3. On the following page, please find a recently published graphic of the LRCCD Governance Structure.

LRCCD Governance Structure Graph



Revised: 9/14/15



Appendix A

MEMORANDUM

Date: September 8, 2015
 To: Committee Chairs
 cc: W. LaNier
 From: Katelynn Rodriguez, Student Senate President
 Subject: Students for Participatory Governance Committees – Fall 2015

We continue to seek students to serve on committees where their representation is lacking (Curriculum, and District committees). Students listed below received your contact and meeting information and have been encouraged to seek your guidance in getting updated on the committee's processes.

Committee Name	Student	Student's Position
Academic Senate	Katelynn Rodriguez: rodriguez.kateLynn11@gmail.com	Student Senate President
Budget	Kelly Melanson: ksmeLanson@gmail.com	Student Ambassador
Budget	Karlee Horton: karLeehorton99@gmail.com	SGVT 300 Student
Campus Sustainability	Jose Patino: patinojose2093@gmail.com	Student Ambassador
College Planning	Brian Gan: b_gan5@hotmail.com	Student Ambassador
College Planning	Priyanka Parmar: pia271914@gmail.com	Student Ambassador
Cultural Competence & Equity	Adrianna Will: Adrianna_wiLL@yahoo.com	Student Ambassador
Cultural Competence & Equity	Alex Anguiano: aleanguiano08@yahoo.com	Student Ambassador
Cultural Competence & Equity	Billie Levingston: bilMcaLL@gmail.com	SGVT 300 Student
Distance Education & Information Technology	Mia Scott: scottdmia@gmail.com	SGVT 300 Student
Distance Education & Information Technology	Priyanka Parmar: pia271914@gmail.com	Student Ambassador
Equity Plan Revision Team	Fredrick Thomas: fredrickthomas03@gmail.com	Student Ambassador
Equity Plan Revision Team	Kelly Melanson: ksmeLanson@gmail.com	Student Ambassador
Executive Council	Katelynn Rodriguez: rodriguez.kateLynn11@gmail.com	Student Senate President
Foundations for Academic Success	Tenley Lillegard: tenLeyLiLlegard@gmail.com	Student Senate Secretary
Health & Facilities	Kisha Harrington: rickishaharrington@gmail.com	SGVT 300 Student
Health & Facilities	Nina Huson: w1559557@apps.losrios.edu	SGVT 300 Student
Professional Development	Merissa Heredia, Merissa.heredia95@gmail.com	SGVT 300 Student
Social Responsibility	Elisabeth Kurtz: eLisabethrosekurtz@gmail.com	SGVT 300 Student
Social Responsibility	Aden Trawick: aden916caLi@yahoo.com	Student Senate Senator
Student Success-Matriculation	Denisha Bland: dbLand03@yahoo.com	Student Ambassador
Student Success-Matriculation	Jose Patino: patinojose2093@gmail.com	Student Ambassador

Appendix A, continued

Additional Participatory Governance at the College

Disciplinary Appeals Committee: In accordance with Regulation 2400 Student Rights and Responsibilities, 2.0 Disciplinary Appeals Committee, the students listed below are recommended for selection to serve on the Disciplinary Appeals Panel (section 2.1.1). Winnie LaNier, ASCRC Advisor maintains a record of student participation to allow an opportunity for all interested students to serve. Therefore, **when there is a need to convene a panel, please notify Winnie** at 691-7669, who will contact the two students.

Student Ambassadors: Denisha Bland, Brian Gan, Jose Patino, Fredrick Thomas, Adrianna Will and Asia Jelks, Club Liaison

Accreditation Team Visit Student Forums: Formation in progress.

CRC Foundation Board of Directors: Student Senate President Rodriguez attends the meetings.

List of Sources

[Cosumnes River College Planning Guide \(2009-2015\) version of the Planning Guide](#)
[Program Overview and Forecast Manual \(PrOF\) previous PrOF Manual](#)
[College Integrated Planning System \(CIPS\) previous url for CIPS](#)
[Unit Plans from 2007, 2009, 2011, and 2013](#)
[Cultural Competency and Equity Strategic Plan](#)
[Professional Development Strategic Plan](#)
[2014-15 Final Achievements \(with benchmarks\)](#)
[Curriculum Handbook](#)
[Brief History of the College's Outcomes Assessment Development Process](#)
[The previous Assessment Outcomes History](#)
[Assessment Guide](#)
[The previous Assessment Guide](#)
[Fall 2015 Convocation Assessment Dialog Notes](#)
[Spring 2015 Convocation Assessment Dialog Notes](#)
[2014 PrOF Data Packets](#)
[2015 PrOF Data Packets](#)
[Facilities Request Process \(2015-17\)](#)
[Facilities Request Form \(2015-17\)](#)
[CRC DE Master Plan](#)
[Participatory Governance Handbook](#)
[Student Senate](#)



**COSUMNES
RIVER COLLEGE**
Los Rios Community College District